

CALL 800-480-6613

SALES SERVICE INTEGRATION
REPAIR INSTALLATION WARRANTY



High Security Series

Product selection guide

High Security LCN closers feature a vandal resistant design engineered for each application, easy installation, and superior performance. This guide is based on the desired mounting of the closer.

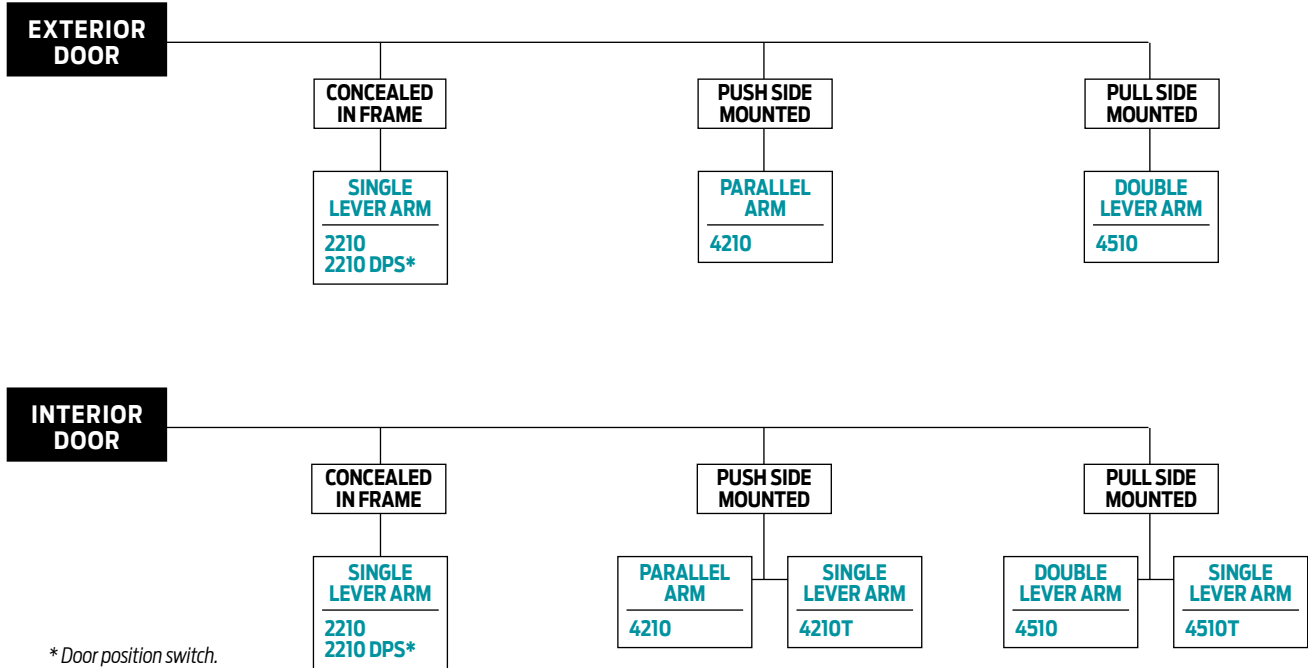

Product comparison

This chart shows a basic comparison of LCN High Security closers. Refer to the specific closer chapter for complete details.

CLOSER SERIES	MOUNTING				FINISH		COVER		CYLINDER				**ARM FUNCTION					
	HINGE (PULL SIDE)	PARALLEL ARM (PUSH)	STOP FACE	CONCEALED (FRAME)	POWDER COAT	PLATED	PLASTIC	METAL	HANDED	NON-SIZED	SIZED	ACCESSIBILITY	DELAYED ACTION	AVB***	DPS SWITCH	STANDARD (SINGLE)	EDA	CUSH/HCUSH
2210	○	○	○	●	●	●	○	○	●	○	●	○	○	○	○	180°	○	○
2210DPS	○	○	○	●	●	●	○	○	●	○	●	○	○	○	○	180°	○	○
4210	○	●	○	○	●	●	○	○	●	●	●	○	○	○	○	180°	110°	○
4210T	○	○	●	○	●	●	○	○	●	○	●	○	○	○	○	110°	○	○
4510	●	○	○	○	●	●	○	○	●	●	●	○	○	○	○	140°	○	○
4510T	●	○	○	○	●	●	○	○	●	○	●	○	○	○	○	180°	○	○

● AVAILABLE
○ NOT AVAILABLE

♿ Closer available with less than 5.0 lbs. opening force on 36" door.
 ** Maximum opening with standard template. See individual closer series for degrees of opening per installation.
 *** Advanced Variable Backcheck.

High Security Closers Series

APPLICATIONS

- For any concealed or surface mounted installation subject to potential abuse or vandalism.
- For correctional, aluminum, hollow metal, or wood doors and frames.
- Can be used with hinge or pivot mounted door.
- Adapter plates and other installation accessories available for unusual conditions.

FEATURES COMMON TO HIGH SECURITY CLOSERS

- Each closer is a vandal resistant design for a specific mounting; hinge side, parallel arm, stop face, or concealed.
- All high security closers are based on a cylinder certified to exceed 10,000,000 cycles in independent testing.
- Handed for right or left swinging doors.
- Closers to meet ADA reduced opening force requirements.
- All closers furnished with TORX tamper resistant machine screws.
- All surface mount closers include a heavy gauge steel cover with four attachment points.
- All closer adjustments are protected when installation is complete.
- All track closers use a jam resistant track and tamper resistant arm/roller assembly.
- Adjustable hydraulic backcheck cushions opening swing prior to 90°.
- Advanced variable backcheck (AVB) is available on all high security closers.
- Separate regulation of general closing speed and latching speed.

DESIGN ASSISTANCE

LCN has been providing reliable solutions to unique door control problems since 1925. Design and specification assistance are only a phone call away. Contact LCN for assistance or technical information at **877-671-7011** or FAX **800-248-1460 (order entry)**, Fax **815-879-1495** for Technical Support.

WARRANTY

High Security Series closers carry a 15 year limited warranty, except for the 2210DPS Series closer that carries a 2 year limited warranty. See General Information Section for complete warranty details.

MATERIALS

- High strength **cast iron** cylinder.
- **Forged steel** main arms and forearms.
- One piece **forged steel** piston.
- LCN's all weather "**Liquid X**" fluid performs to temperature ranges from 120°F (49°C) to -30°F (-35°C) without any seasonal adjustment.
- **High efficiency, full complement**, low friction bearings.
- **Double heat treated** pinions.
- Tamper resistant regulating screws.
- Full rack and pinion hydraulic action.
- Quiet, low friction track and roller combination for all single lever arm closers.

FINISHES

- Available in six standard or a wide selection of optional custom powder coat finishes to blend with door and frame.
- LCN's powder coat finishes surpass 100 hours of salt spray which is over four times the ANSI standard for corrosion resistance.
- For installations where a higher level of corrosive resistance is required, LCN offers an optional special rust inhibiting (SRI) pre-treatment. Closers that combine the exclusive LCN powder coat finish and the SRI

pre-treatment exceed the ANSI standard for corrosion resistance even further.

- Plated finishes are available as an option to accent door and frame.

LISTINGS & APPROVALS

UL listed for self-closing doors without hold-open under "SWINGING DOOR CLOSERS"(GVEV) file R 1943.

Tested and certified under ANSI Standard A 156.4. Consult factory for details.

Consult factory for other listings such as; ULC, California State Fire Marshal, Bureau of Standards and Appeals.

POSITIVE PRESSURE

LCN closers have been certified for three hours by UL to be in compliance with UL 10 C. Contact LCN for specific details on door closer fire ratings.

FASTENERS

TORX MACHINE SCREW (TORX) pack contains tamper resistant machine screws to install the closer. Thru Bolts for TORX machine screws are available for all high security closers, except 2210 series.

LCN thru bolts (TB) can be installed on 1-3/4" thick doors with the 1/4-20 TORX screws supplied with the closer. Optional sizes are available for 1-5/8" or 1-3/8" door thicknesses, but this must be specified when ordering.

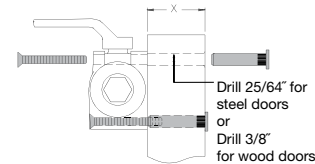

Note 1: For Thru Bolts, specify door thickness if other than 1-3/4" (44mm).

Special driver bits are required for installation or removal of TORX machine screws with a security pin as supplied with LCN High Security closers. All bits fit a 1/4" hex drive socket. For 1/4-20 screws use T-27, for #12 machine screws use T-25, for 10# machine screws use T20, for #8 (and undercut #10) machine screws use T15, and for #6 machine screws use T10. The specific bits required for installation are listed on the "HOW TO ORDER" page for each closer. Sold separately.

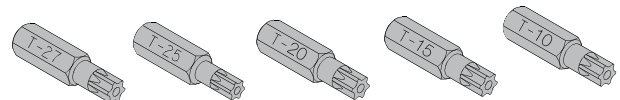

FASTENERS

TORX MACHINE SCREW (TORX) pack contains tamper resistant machine screws to install the closer. Thru Bolts for TORX machine screws are available for all high security closers, except 2210 series.

SPECIFICATIONS

Refer to "SPECIFICATIONS" section for suggested architectural specifications.

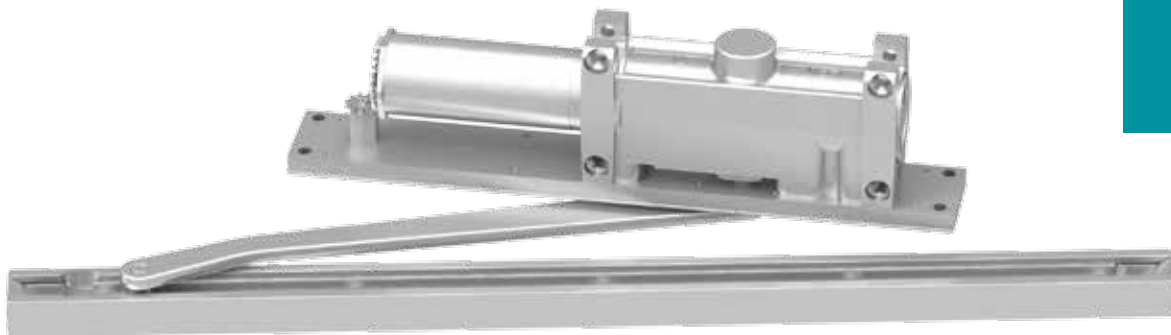

The concealed 2210 Series, heavy duty, high security track closer features complete concealment with special components to minimize tampering and vandalism. Forged steel, single lever arm and heavy steel mounting plate are designed for correctional, vandal prone, institutional, and other high traffic applications. A choice of finishes and cylinder functions meet correctional and vandal resistant requirements.

Certifications	Grade 1 - ANSI A156.4, UL 10C, ADA, 100 Hour Salt Spray, Meets BAA - Buy American Act	Cover	Metal, standard
Body Construction	<ul style="list-style-type: none"> Cast Iron Body Full Complement Bearing 1-1/2" Diameter Piston 11/16" Diameter Double Heat Treated Pinion Journal 	Fasteners	TORX machine screw pack
Fluid	All Weather Liquid X Fluid	Mounting	<ul style="list-style-type: none"> Concealed, single acting cylinder in head frame Concealed, arm and track in top rail of door
Handing	Handed	Arms	Standard security arm and security track
Size	Sized, interior, exterior and vestibule 3-5 (refer to chart)	Finishes/Colors/ Powder Coat	<ul style="list-style-type: none"> Aluminum (689) Statuary Bronze (690) Light Bronze (691) Black (693) Dark Bronze (695) Brass (696) Custom colors optional Optional SRI primer - powder coat only Optional plated finishes
Warranty	15 years (2210); 2 years (2210DPS)		

Special Templates

Customized installation templates or products may be available to solve unusual applications. Contact LCN Product Support for assistance.

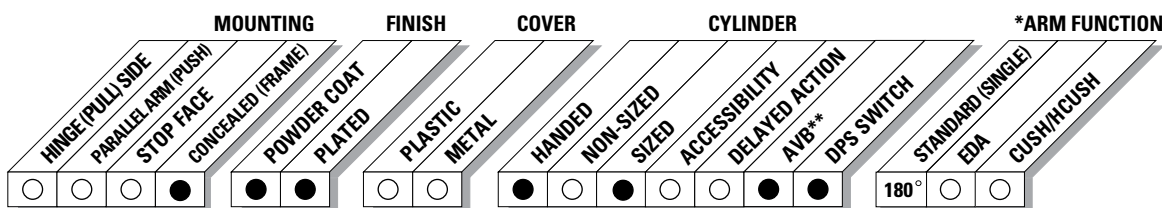

● AVAILABLE
○ NOT AVAILABLE

* Maximum opening with standard template.
** Advanced Variable Backcheck.

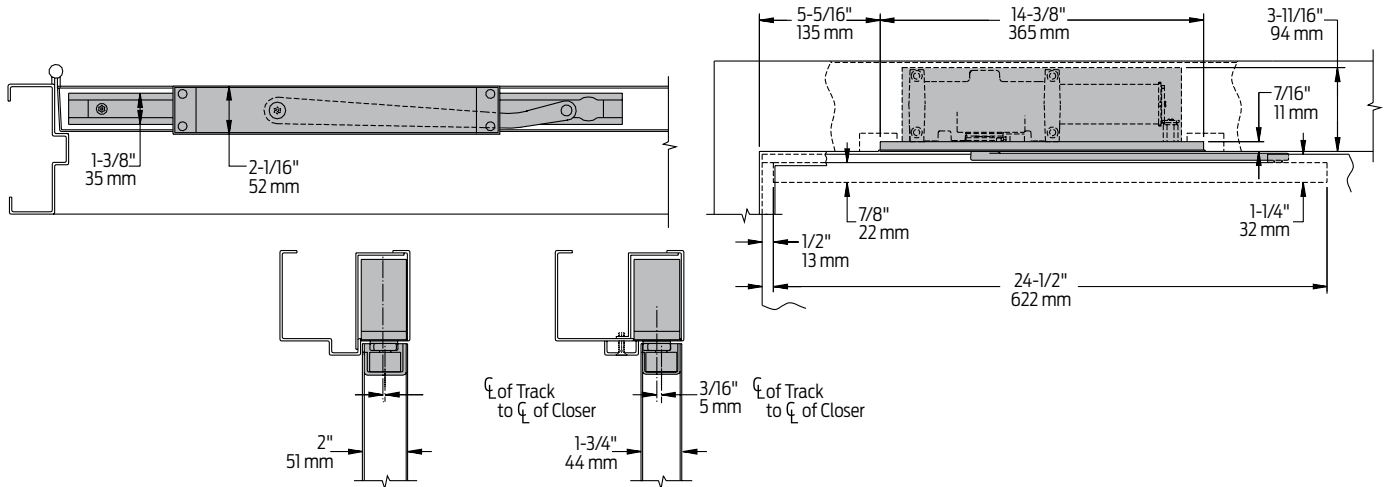

Butt Hinges	Should not exceed 4-1/2" (114 mm) in width
Auxiliary Stop	Recommended where a door cannot swing 180°
Top Rail	1-1/4" (32 mm) mortise required. 3/8" (10 mm) cutout required at top of door, stop face only
Door Thickness	1-3/4" (44 mm) minimum
Door Width	28" (711 mm) minimum
Head Frame	<ul style="list-style-type: none"> 5-3/4" (146 mm) wide and 4" (102 mm) high with 2-3/16" (56 mm) rabbet required Consult factory if any dimension is less
Steel Mounting Plate	Thickness 3/8" (10 mm)
Door Position Switch	<ul style="list-style-type: none"> Optional, newly redesigned, field adjustable switch can interface with security and monitoring systems Add suffix "DPS" to selected cylinder Provides normally open (N.O.) and normally closed (N.C.) circuit A three wire connector harness with 84" (2134 mm), 16 AWG leads is furnished to simplify connection to field wiring Single pole double throw (SPDT) contacts rated at 125/250 VAC at 10.1 amps maximum resistive load are standard
Advanced Variable Backcheck	<ul style="list-style-type: none"> Cylinder starts backcheck at approximately 45° instead of the normal 75° Add suffix "AVB" to selected cylinder (eg. 2213 DPS AVB)
Maximum Opening	<ul style="list-style-type: none"> Templating allows 180° Consult factory if door will be held open at 180° Pivot mounting door limits opening to 110° and increases minimum door width to 32" (813 mm). Consult factory Please note that many track style door closers are capable of allowing 180° of door swing <p><i>Note: Track style closers are at their weakest closing force at 180°. Consult factory for applications where door must swing 180°.</i></p>
Options	<ul style="list-style-type: none"> Advanced Variable Backcheck Cylinder Door Position Switch

Cylinder



2213(4)(5)-3071
Cylinder Assembly

- Handed
- Cast iron
- Standard



2210DPS-3071
Cylinder Assembly

- Handed
- Cast iron

Arms



2210-3077T
2210DPS-3077T
Standard Security Arm

- Handed
- Solid forged steel and large cross section for potentially abusive installations
- Special threaded attachment of track roller for extra security
- Double slab arm/pinion attachment for maximum strength

- Can only be used with high security track roller, 2210-3034 or 2210DPS-3034
- Roller is included with arm when either the 2210-3077T or 2210DPS-3077T are ordered separately

Tracks



2210-3038
Security Track

- Non-handed
- Hold-open function not available
- Designed to eject foreign objects placed in track during either opening or closing motion
- Requires track roller, 2210-3034



2210DPS-3038

Finish Plates



2210-11
Long Plate

- Heavy gauge metal plate
- Required for complete enclosure
- Six point TORX® mounting screws for extra security
- Closer adjustments not accessible with finish plates installed



2210-12
Short Plate

- Heavy gauge metal plate
- Required for complete enclosure
- Four point TORX® mounting screws for extra security
- Closer adjustments not accessible with finish plates installed

Installation Accessories



2210-3034
Security Track Roller

- Low friction track roller threads into 2210-3077T arm for extra strength and security
- Can not be removed without disconnecting arm from closer

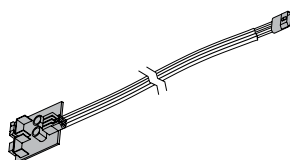

2210-493
Test Kit

- Battery operated designed to verify switch signal response point
- Can be used directly at door location (used for 2210 DPS only)

How-to-order 2210 Series closers

Select cylinder size

- 2213
- 2213 DPS
- 2214
- 2214 DPS
- 2215
- 2215 DPS

Select hand

- RH
- LH

Specify finish

- Standard Powder Coat _____
Aluminum, Dark Bronze, Statuary, Light Bronze, Black, Brass

Closer will be shipped with:

- Standard cylinder
- Finish plate
- Standard security arm
- Security track roller
- Security track
- TORX machine screw pack, unless options listed below are selected.

Closer options

Cylinder

- Advanced Variable Backcheck (AVB)

Finishes

- Custom Powder Coat (RAL) _____
- Plated Finish, US _____ (cover plate and arm only)
- SRI primer (excludes DPS) (use with powder _ coat finishes only)

Special template

- ST- _____

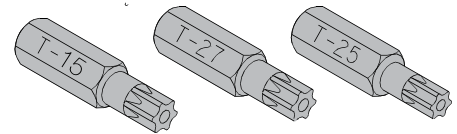

NOTE: Installation of this closer requires T-27, T-25 and T-15 driver bits for TORX machine screws with a security pin. Sold separately.

Table of sizes

- Select closer based on width of door
- 2210 Series cylinders available in size 3, 4, or 5
- Spring power is set at the factory for size 3, 4, or 5, but is field adjustable (may be increased 50%)

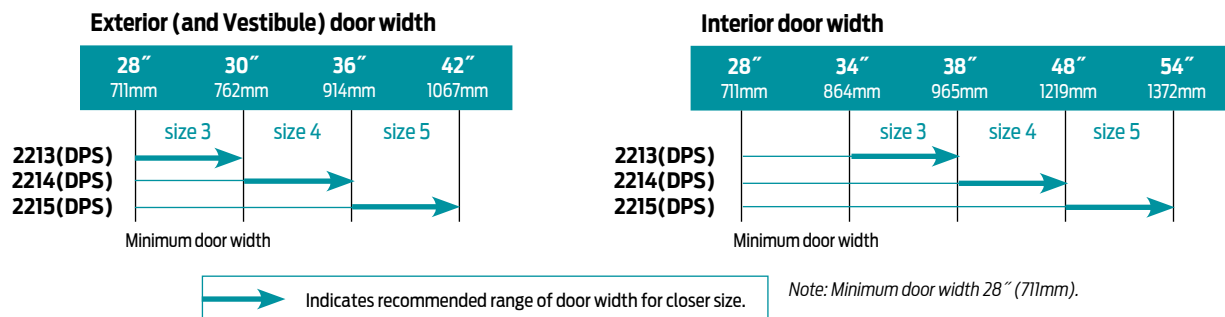

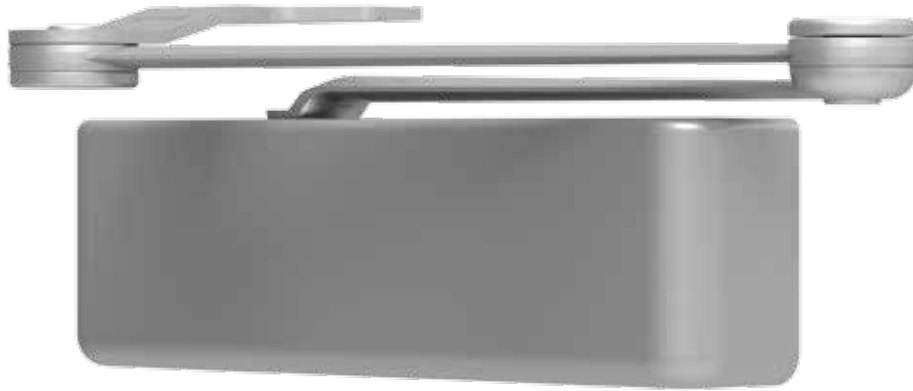

The 4210 SMOOTHIE® Series is a heavy duty, high security closer with special components to minimize tampering and vandalism. Forged steel parallel arms and heavy gauge metal security covers are designed for correctional, vandal prone, institutional and other high traffic applications. The closer has passed 10 million cycles in independent testing. A choice of finishes and cylinder functions meet correctional and vandal resistant requirements.

Certifications	Grade 1 - ANSI A156.4, UL 10C, ADA*, 100 Hour Salt Spray, Meets BAA - Buy American Act <i>*4211 cylinder meets ADA</i>	Cover	Metal Security
Body Construction	<ul style="list-style-type: none"> Cast Iron Body Full Complement Bearing 1-1/2" Diameter Piston 11/16" Diameter Double Heat Treated Pinion Journal 	Fasteners	TORX machine screw pack
Fluid	All Weather Fluid	Mounting	Parallel (Push Side)
Handing	Handed	Arms	Extra duty, non hold-open
Size	<ul style="list-style-type: none"> Adjustable Exterior and, Vestibule, Size 3-5 or size 6 Adjustable, Interior, Size 2-5; or size 6 	Finishes/Colors/ Powder Coat	<ul style="list-style-type: none"> Aluminum (689) Statuary Bronze (690) Light Bronze (691) Black (693) Dark Bronze (695) Brass (696) Custom colors optional
Warranty	15 years		<ul style="list-style-type: none"> Optional SRI primer - powder coat only Optional plated finishes (cover only)

Special Templates

Customized installation templates or products may be available to solve unusual applications. Contact LCN Product Support for assistance.

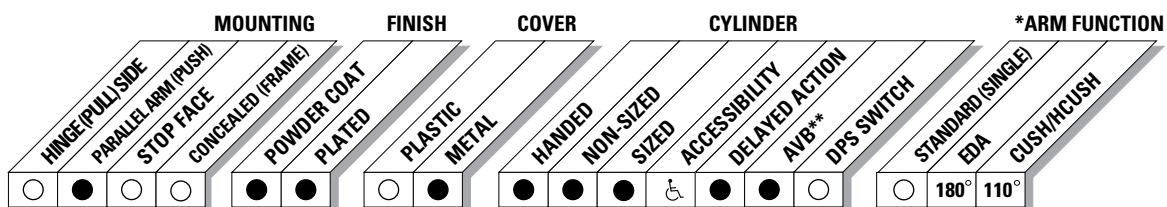

● AVAILABLE
○ NOT AVAILABLE

♿ Closer available with less than 5.0 lbs. opening force on 36" door.
* Maximum opening with standard template. See individual closer series for degrees of opening per installation.
** Advanced Variable Backcheck.

4210 Series

Mounting details

Parallel Arm (Push Side) Mounting

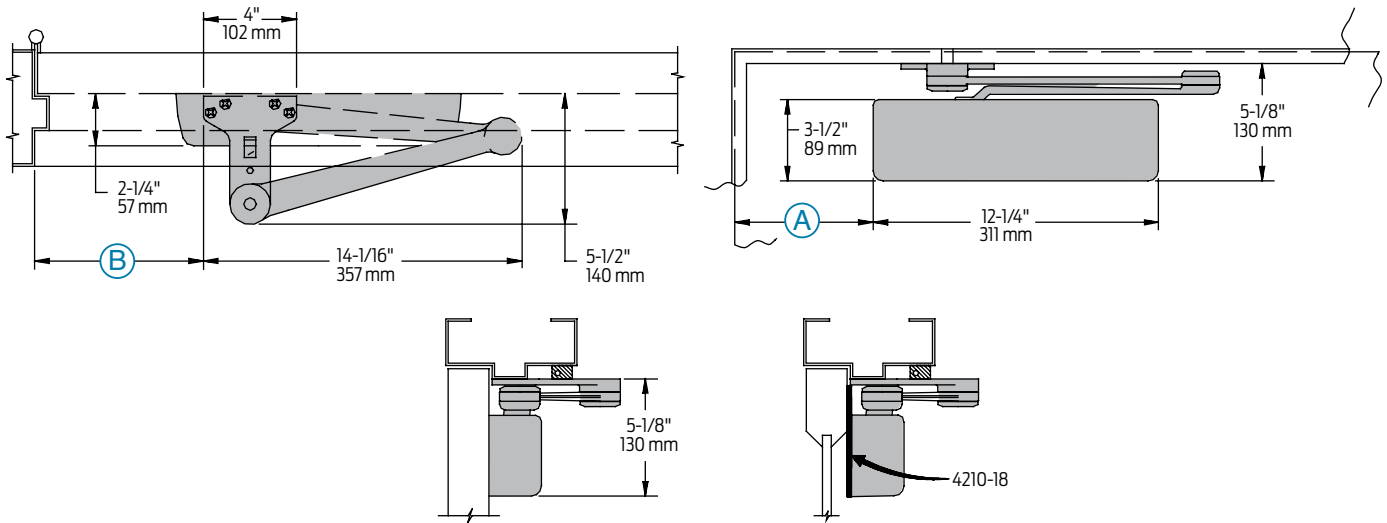

Butt Hinges	Should not exceed 5" (127 mm) in width															
Auxiliary Stop	Recommended where the door cannot swing 180° or where CUSH arms not used															
Clearance	For EDA or CUSH is 5-1/2" (140 mm) from push side of door															
Top Rail	Less than 5-1/8" (130 mm) measured from stop, requires PLATE 4210-18. Plate requires 2" (51 mm) minimum top rail															
Stop Width	2-3/4" (70 mm) recommended. Less than 1" (25mm), consult factory															
Delay Action	<ul style="list-style-type: none"> ■ Add suffix "DEL" to selected cylinder (eg. 4211DEL) ■ Not available with 4215 or 4216 cylinder ■ Delays closing from maximum opening to approximately 70° ■ Delays time adjustable up to approximately 1 minute 															
Advanced Variable Backcheck	<ul style="list-style-type: none"> ■ Cylinder starts backcheck at approximately 45° instead of the normal 75° ■ Add suffix "AVB" to selected cylinder (eg. 4211 AVB) 															
Maximum opening	<table border="1"> <thead> <tr> <th></th> <th>EDA arm can be templated for</th> <th>CUSH arm can be templated for maximum opening at</th> </tr> </thead> <tbody> <tr> <td>100°:</td> <td>A = 5-15/16" (151 mm) B = 7-1/4" (184 mm)</td> <td>85°: A = 8-5/16" (211 mm) B = 9-5/8" (244 mm)</td> </tr> <tr> <td>140°:</td> <td>A = 4-7/16" (113 mm) B = 5-3/4" (146 mm)</td> <td>90°: A = 7-11/16" (195 mm) B = 9" (229 mm)</td> </tr> <tr> <td>180°:</td> <td>A = 2-15/16" (75 mm) B = 4-1/4" (108 mm)</td> <td>100°: A = 6-7/16" (164 mm) B = 7-3/4" (197 mm)</td> </tr> <tr> <td></td> <td></td> <td>110°: 5-9/16" (141 mm) B = 6-7/8" (175 mm)</td> </tr> </tbody> </table>		EDA arm can be templated for	CUSH arm can be templated for maximum opening at	100°:	A = 5-15/16" (151 mm) B = 7-1/4" (184 mm)	85°: A = 8-5/16" (211 mm) B = 9-5/8" (244 mm)	140°:	A = 4-7/16" (113 mm) B = 5-3/4" (146 mm)	90°: A = 7-11/16" (195 mm) B = 9" (229 mm)	180°:	A = 2-15/16" (75 mm) B = 4-1/4" (108 mm)	100°: A = 6-7/16" (164 mm) B = 7-3/4" (197 mm)			110°: 5-9/16" (141 mm) B = 6-7/8" (175 mm)
	EDA arm can be templated for	CUSH arm can be templated for maximum opening at														
100°:	A = 5-15/16" (151 mm) B = 7-1/4" (184 mm)	85°: A = 8-5/16" (211 mm) B = 9-5/8" (244 mm)														
140°:	A = 4-7/16" (113 mm) B = 5-3/4" (146 mm)	90°: A = 7-11/16" (195 mm) B = 9" (229 mm)														
180°:	A = 2-15/16" (75 mm) B = 4-1/4" (108 mm)	100°: A = 6-7/16" (164 mm) B = 7-3/4" (197 mm)														
		110°: 5-9/16" (141 mm) B = 6-7/8" (175 mm)														

Hold-open point at maximum opening with H-CUSH arm.

Options

- Delayed Action or Advanced Variable Backcheck cylinder.

Cylinder



4211(6)-3071
Cylinder Assembly

- Handed
- Cast iron
- Standard

Cover



4210-72MC
Metal Security Cover

- Handed
- Four point mounting for extra security
- Closer adjustments not accessible with cover installed
- Standard

Arms



4210-3077EDA
Extra Duty Arm

- Non-handed
- Parallel arm features solid forged steel main arm and forearm for potentially abusive installations
- Double slab arm/pinion attachment for maximum strength



4210-3077CNS
Cush-N-Stop® (CUSH) Arm

- Non-handed
- Parallel arm features solid forged steel main arm and forearm with built-in stop in soffit shoe
- Double slab arm/pinion attachment for maximum strength



4210-3049CNS
HCUSH Arm

- Non-handed
- Parallel arm provides hold-open function with templated stop/hold-open points
- Handle controls hold-open function with thumb turn
- HCUSH arm not available with 4216 cylinder
- Double slab arm/pinion attachment for maximum strength

Installation Accessories



4210-18, 4210-18CUSH
Plate

- Required for push side mount where top rail is less than 5-1/8" (130 mm), measured from the stop
- Requires 2" (51 mm) minimum top rail measured from the stop.
- Also used with CUSH arm installations



4210-30
CUSH Shoe Support

- Provides anchorage for fifth screw used with CUSH arms where reveal is less than 3-1/16" (78mm)



4210-61
Blade Stop Spacer

- Lowers parallel arm shoe to clear 1/2" (13 mm) blade stop



4210-419
PA Flush Panel Adapter

- Provides horizontal mounting surface for EDA or CUSH shoe on single rabbetted or flush frame

How-to-order 4210 Series

Select cylinder size

- 4211 (adjustable from size 1 to 5)
- 4216 (DEL or HCUSH arm not available)

Select hand

- RH
- LH

Specify finish

- Standard Powder Coat _____
Aluminum, Dark Bronze, Statuary, Light Bronze, Black, Brass

Closer will be shipped with:

- Standard cylinder
- Security cover
- Standard security arm
- TORX machine screw pack, unless options listed below are selected.

NOTE: Installation of this closer requires T-27 and T-25 driver bits for TORX machine screws with a security pin. Sold separately.

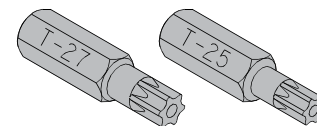

Closer options

Cylinder

- Delayed Action (DEL)
- Advanced Variable Backcheck (AVB)

Finishes

- Custom Powder Coat (RAL) _____
- Plated Finish, US _____ (cover only)
- SRI primer (excludes DPS) (use with powder coat finishes only)

Arms

- Cush-N-Stop arm (CUSH)
- HCush-N-Stop arm (HCUSH)

Screw pack

- TB* and TORX Machine Screw (TBTRX)
*Specify door thickness if other than 1-3/4".

Installation accessories

- PLATE, 4210-18
- PLATE, 4210-18CUSH

Special template

- ST- _____

Table of sizes

- Select closer based on width of door
- The spring power of non-sized 4211 cylinder is adjustable from size 1 through size 5 and is shipped set to size 3
- Sized 4210 Series cylinder available in size 6
- Delayed action not available with 4216 cylinder

Exterior (and Vestibule) door width

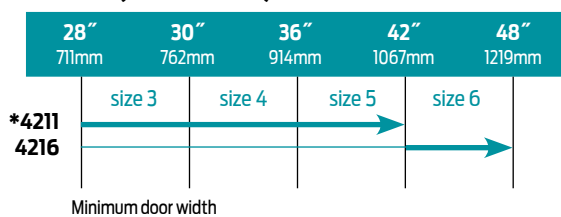

Interior door width

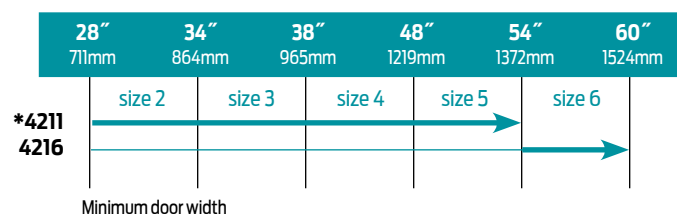

→ Indicates recommended range of door width for closer size. * Adjustable Size 1 thru 5

Reduced opening force 4210 Series closers

CAUTION! Any manual door closer, including those certified by BHMA to conform to ANSI Standard A156.4, that is selected, installed and adjusted based on ADA or other reduced opening force requirements may not provide sufficient power to reliably close and latch a door.

Refer to POWER OPERATORS section for information on systems that meet reduced opening force requirements without affecting closing power.

* Maximum opening force.

	DOOR WIDTH	36"	42"	48"
	8.5* lbs.	4211	4211	4211
5.0* lbs.	4211	4211	4211	

* Maximum opening force.



The 4210T SMOOTHIE® Series is a heavy duty, high security track closer with special components to minimize tampering and vandalism. Forged steel arms and heavy gauge metal security covers are designed for correctional, vandal prone, institutional and other high traffic interior applications. The closer has passed 10 million cycles in independent testing. A choice of finishes and cylinder functions meet correctional and vandal resistant requirements.

Certifications	Grade 1 - ANSI A156.4, UL 10C, ADA*, 100 Hour Salt Spray, Meets BAA - Buy American Act <i>*4211 meeting ADA requirements</i>	Cover	Metal Security
Body Construction	<ul style="list-style-type: none"> ■ Cast Iron Body ■ Full Complement Bearing ■ 1-1/2" Diameter Piston ■ 11/16" Diameter Double Heat Treated Pinion Journal 	Fasteners	TORX machine screw pack
Fluid	All Weather Fluid	Mounting	Stop Face (Push Side)
Handing	Handed	Arms	Security arm, security track with roller
Size	Interior, Sized 1, 3 or 4	Finishes/Colors/ Powder Coat	<ul style="list-style-type: none"> ■ Aluminum (689) ■ Statuary Bronze (690) ■ Light Bronze (691) ■ Black (693) ■ Dark Bronze (695) ■ Brass (696) ■ Custom colors optional
Warranty	15 years		<ul style="list-style-type: none"> ■ Optional SRI primer - powder coat only ■ Optional plated finishes

Special Templates

Customized installation templates or products may be available to solve unusual applications. Contact LCN Product Support for assistance.

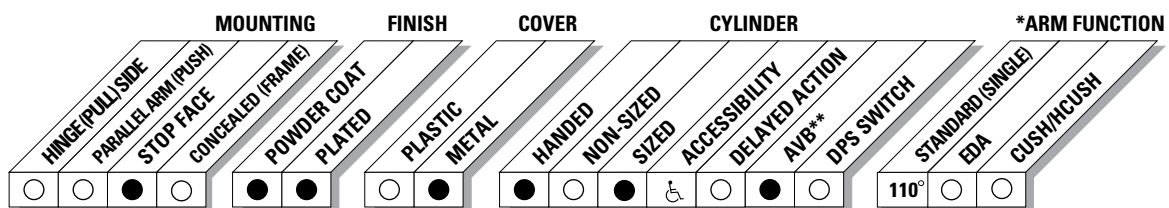

● AVAILABLE
○ NOT AVAILABLE

♿ Closer available with less than 5.0 lbs. opening force on 36" door.
* Maximum opening with standard template.
** Advanced Variable Backcheck.

4210T Series

Mounting details

Stop Face (Push Side) Mounting

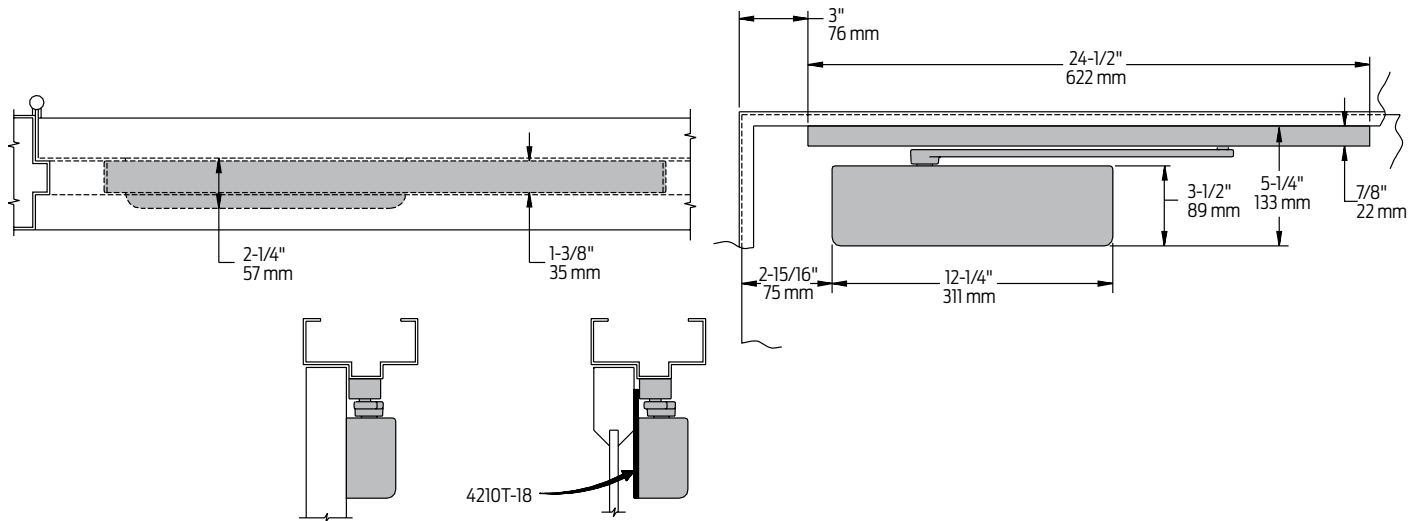

Butt Hinges	Should not exceed 5" (127 mm) in width
Auxiliary Stop	Recommended where the door cannot swing 110°
Clearance	2-1/4" (57 mm) from door
Top Rail	<ul style="list-style-type: none"> Less than 5-1/4" (133 mm) measured from stop, requires PLATE 4210T-18 Plate requires 2-1/4" (57mm) minimum measured from the stop
Stop Width	Minimum 1-3/8" (35 mm)
Advanced Variable Backcheck	<ul style="list-style-type: none"> Cylinder starts backcheck at approximately 45° instead of the normal 75° Add suffix "AVB" to selected cylinder (eg. 4213T AVB)
Maximum opening	Templating allows 110°
Options	Advanced Variable Backcheck cylinder

Cylinder



4211(3)(4)T-3071 Cylinder Assembly

- Handed
- Cast iron
- For various applications see "Table of Sizes" on 4210T Series page 14
- Standard

Cover



4210T-72MC Metal Security Cover

- Handed
- Four point TORX mounting for extra security
- Closer adjustments not accessible with cover installed

Arms



4210T-3077T Standard Security Arm

- Handed
- Solid forged steel, large cross section arm
- Special threaded attachment of track roller for extra security
- Double slab arm/pinion attachment for maximum strength
- Can only be used with high security track roller, 4210T-3034

Track



4210T-3038 Security Track

- Non-handed
- Designed to eject foreign objects placed in track during either opening or closing motion
- Requires track roller, 4210T-3034



4210T-3034 Security Track Roller

- Low friction track roller threads into 4210T-3077 arm for extra strength and security
- Can not be removed without disconnecting arm from closer

Installation Accessories



4210T-18 Plate

- Required where top rail, when measured from the stop, is less than 5-1/4" (133 mm)
- Requires 2-1/4" (57 mm) minimum top rail measured from the stop

How-to-order 4210T Series

Select cylinder size

- 4211T (ADA)
- 4213T
- 4214T

Select hand

- RH
- LH

Specify finish

- Standard Powder Coat _____
Aluminum, Dark Bronze, Statuary, Light Bronze, Black, Brass

Closer will be shipped with:

- Standard cylinder
- Security cover
- Standard security arm
- Security track roller
- Security track
- TORX machine screw pack, unless options listed below are selected.

NOTE: Installation of this closer requires T-27 and T-25 driver bits for TORX machine screws with a security pin. Sold separately.

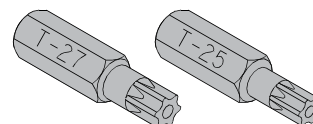

Closer options

Cylinder

- Advanced Variable Backcheck (AVB)

Finishes

- Custom Powder Coat (RAL) _____
- Plated Finish, US _____
- SRI primer (excludes DPS) (use with powder coat finishes only)

Screw pack

- TB* and TORX Machine Screw (TBTRX)
*Specify door thickness if other than 1-3/4".

Installation accessories

- PLATE, 4210T-18

Special template

- ST- _____

Table of sizes

- Select closer based on width of door
- 4210T series cylinders available in size 1, 3 or 4
- Closing power of all 4210T Series closers may be increased 15%

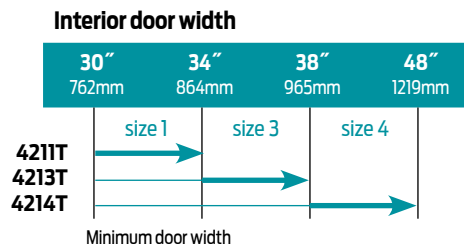

→ Indicates recommended range of door width for closer size. Note: Minimum door width 30" (762mm).

Reduced opening force 4210T Series closers

CAUTION! Any manual door closer, including those certified by BHMA to conform to ANSI Standard A156.4, that is selected, installed and adjusted based on ADA or other reduced opening force requirements may not provide sufficient power to reliably close and latch a door.

Refer to POWER OPERATORS section for information on systems that meet reduced opening force requirements without affecting closing power.

* Maximum opening force.

	DOOR WIDTH	36"	42"	48"
	8.5* lbs.	4213T	4213T	4213T
	5.0* lbs.	4211T	4211T	4211T

* Maximum opening force.

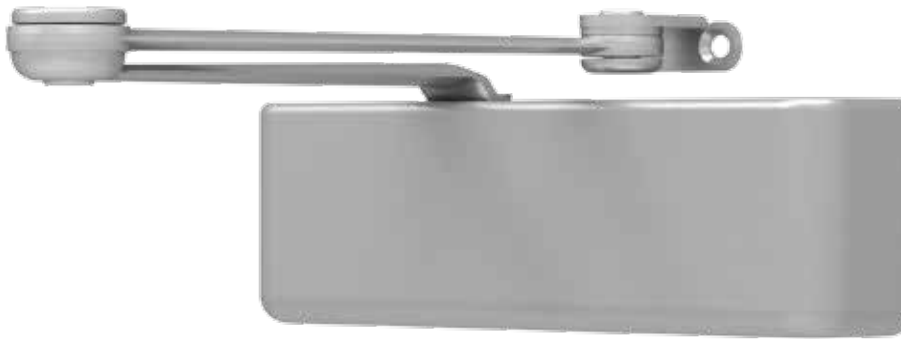

The 4510 SMOOTHEE® Series is a heavy duty, high security closer with special components to minimize tampering and vandalism. Forged steel double lever arms and heavy gauge metal security covers are designed for correctional, vandal prone, institutional and other high traffic applications. The closer has passed 10 million cycles in independent testing. A choice of finishes and cylinder functions meet correctional and vandal resistant requirements.

Certifications	Grade 1 - ANSI A156.4, UL 10C, ADA*, 100 Hour Salt Spray, Meets BAA - Buy American Act	Cover	Metal Security
	<i>*4511 cylinder meets ADA requirements</i>	Fasteners	TORX machine screw pack
Body Construction	<ul style="list-style-type: none"> ■ Cast Iron Body ■ Full Complement Bearing ■ 1-1/2" Diameter Piston ■ 11/16" Diameter Double Heat Treated Pinion Journal 	Mounting	Hinge (Pull Side)
Fluid	All Weather Fluid	Arms	Extra heavy duty, non-hold open
Handing	Handed	Finishes/Colors/ Powder Coat	<ul style="list-style-type: none"> ■ Aluminum (689) ■ Statuary Bronze (690) ■ Light Bronze (691) ■ Black (693) ■ Dark Bronze (695) ■ Brass (696) ■ Custom colors optional
Size	Exterior and Vestibule, Adjustable Size 1-5 Interior, Adjustable Size 1-5		<ul style="list-style-type: none"> ■ Optional SRI primer - powder coat only ■ Optional plated finishes
Warranty	15 years		

Special Templates

Customized installation templates or products may be available to solve unusual applications. Contact LCN Product Support for assistance.

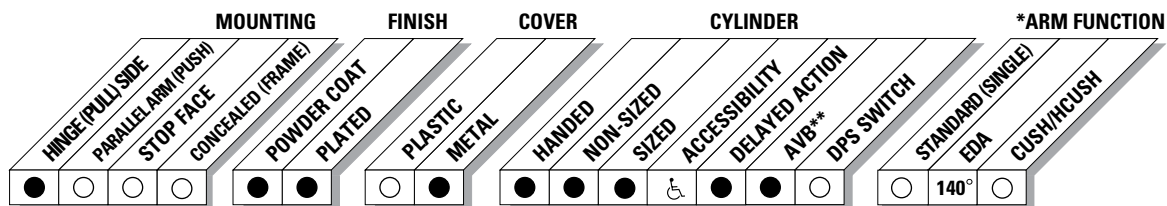

● AVAILABLE
○ NOT AVAILABLE

♿ Closer available with less than 5.0 lbs. opening force on 36" door.
* Maximum opening with standard template.
** Advanced Variable Backcheck.

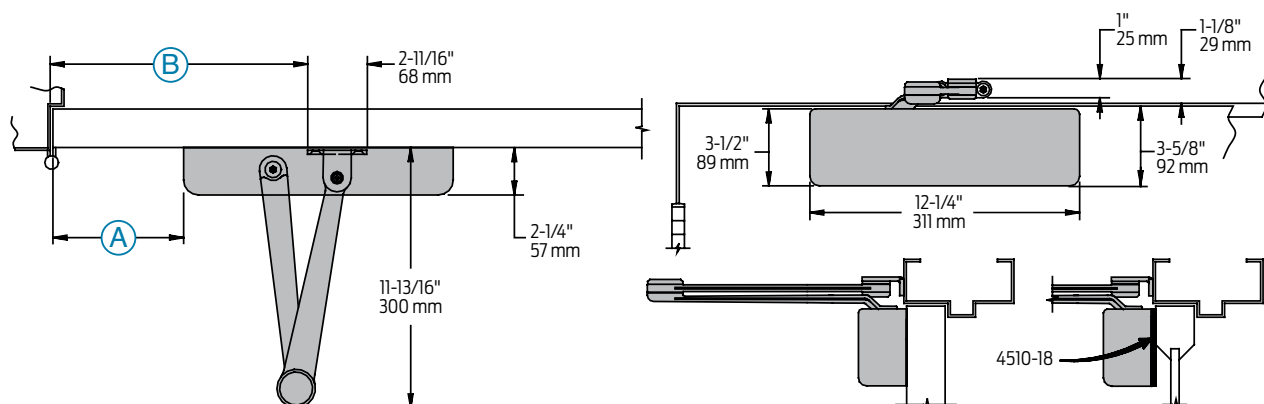

Butt Hinges	Should not exceed 5" (127 mm) in width
Auxiliary Stop	Recommended where a door cannot swing 140°
Reveal	Should not exceed 1/8" (3 mm)
Top Rail	<ul style="list-style-type: none"> Less than 3-1/2" (89 mm), requires PLATE 4510-18 Plate requires 2" (51mm) minimum top rail
Head Frame	Less than 1" (25 mm), consult factory
Clearance	2-1/4" (57 mm) behind door required for installation
Arm Clearance	Above door 1-1/8" (29 mm) required
Delay Action	<ul style="list-style-type: none"> Add suffix "DEL" to selected cylinder. Not available with 4516 cylinder. Delays closing from maximum opening to approximately 70°. Delay time adjustable up to approximately 1 minute.
Advanced Variable Backcheck	<ul style="list-style-type: none"> Cylinder starts backcheck at approximately 45° instead of the normal 75° Add suffix "AVB" to selected cylinder
Maximum opening	Can be templated for 140°: A = 4-3/16" (106 mm) B = 9-7/8" (251 mm)
Options	<ul style="list-style-type: none"> Delayed action or Advanced Variable Backcheck cylinder

Cylinder



4511(6)-3071
Cylinder Assembly

- Handed
- Cast iron
- Standard

Cover



4510-72MC
Metal Security Cover

- Handed
- Four point mounting for extra security
- Closer adjustments not accessible with cover installed
- Standard

Arms



4510-3077EDA
Extra Duty Arm

- Non-handed
- Solid forged steel main arm and forearm for potentially abusive installations
- Double slab arm/pinion attachment for maximum strength
- Standard

Installation Accessories



4510-18
Plate

- Required where top rail is less than 3-1/2" (89 mm)
- Requires minimum 2" (51 mm) top rail

How-to-order 4510 Series

Select cylinder size

- 4511 (adjustable from size 1 to 5)
- 4516 (DEL not available)

Select hand

- RH
- LH

Specify finish

- Standard Powder Coat _____
Aluminum, Dark Bronze, Statuary, Light Bronze, Black, Brass

Closer will be shipped with:

- Standard cylinder
- Security cover
- Extra duty arm
- TORX machine screw pack, unless options listed below are selected.

NOTE: Installation of this closer requires T-27 and T-25 driver bits for TORX machine screws with a security pin. Sold separately.

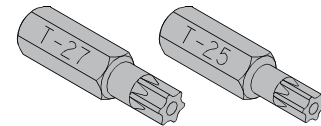

Closer options

Cylinder

- Delayed Action (DEL)
- Advanced Variable Backcheck (AVB)

Finishes

- Custom Powder Coat (RAL) _____
- Plated Finish, US _____
- SRI primer (use with powder coat finishes only)

Screw pack

- TB* and TORX Machine Screw (TBTRX)
*Specify door thickness if other than 1-3/4".

Installation accessories

- PLATE, 4510-18

Special template

- ST- _____

Table of sizes

- Select closer based on width of door
- The spring power of non-sized 4511 cylinder is adjustable from size 1 through size 5 and is shipped set to size 3
- Sized 4510 Series cylinder available in size 6
- Delayed action not available with 4516 cylinder

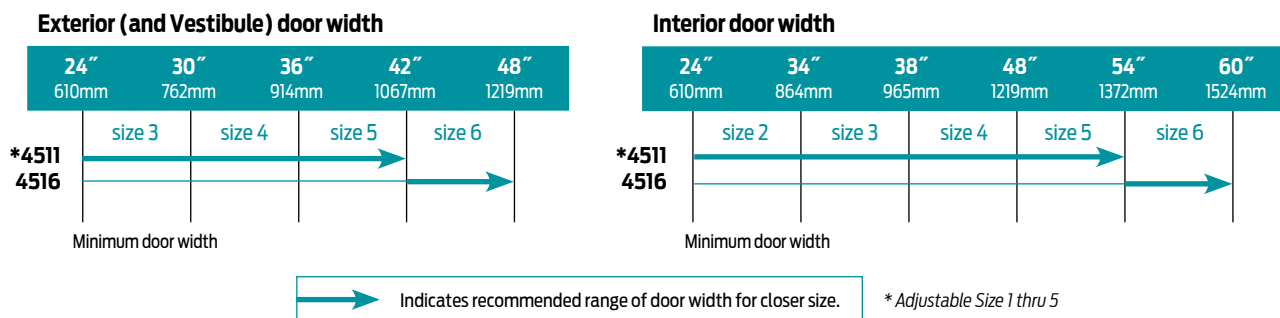

Reduced opening force 4510 Series closers

CAUTION! Any manual door closer, including those certified by BHMA to conform to ANSI Standard A156.4, that is selected, installed and adjusted based on ADA or other reduced opening force requirements may not provide sufficient power to reliably close and latch a door.

Refer to POWER OPERATORS section for information on systems that meet reduced opening force requirements without affecting closing power.

* Maximum opening force.

	DOOR WIDTH	36"	42"	48"
	8.5* lbs.	4511	4511	4511
5.0* lbs.	4511	4511	4511	

* Maximum opening force.



The 4510T SMOOTHIE® Series is a heavy duty, high security track closer with special components to minimize tampering and vandalism. Forged steel single lever arm and heavy gauge metal security cover are designed for correctional, vandal prone, institutional and other high traffic interior applications. The closer has passed 10 million cycles in independent testing. A choice of finishes and cylinder functions meet correctional and vandal resistant requirements.

Certifications	Grade 1 - ANSI A156.4, UL 10C, ADA*, 100 Hour Salt Spray, Meets BAA - Buy American Act <i>*4510T cylinder meets ADA requirements</i>	Cover	Metal Security
Body Construction	<ul style="list-style-type: none"> ■ Cast Iron Body ■ Full Complement Bearing ■ 1-1/2" Diameter Piston ■ 11/16" Diameter Double Heat Treated Pinion Journal 	Fasteners	TORX machine screw pack
Fluid	All Weather Fluid	Mounting	Hinge (Pull Side)
Handing	Handed	Arms	Standard security arm, security track (non hold-open) and track roller
Size	Sized, 1, 3 or 4	Finishes/Colors/ Powder Coat	<ul style="list-style-type: none"> ■ Aluminum (689) ■ Statuary Bronze (690) ■ Light Bronze (691) ■ Black (693) ■ Dark Bronze (695) ■ Brass (696) ■ Custom colors optional
Warranty	15 years		<ul style="list-style-type: none"> ■ Optional SRI primer - powder coat only ■ Optional plated finishes

Special Templates

Customized installation templates or products may be available to solve unusual applications. Contact LCN Product Support for assistance.

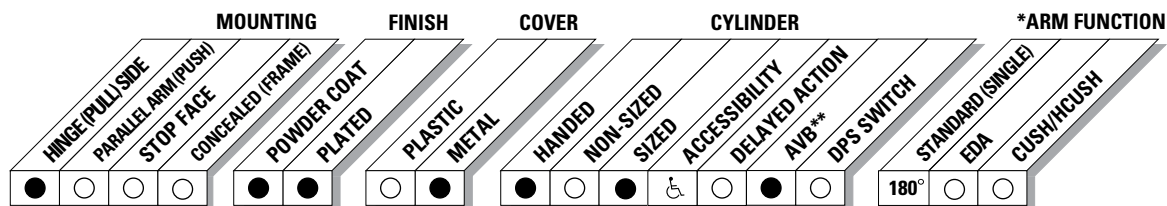

● AVAILABLE
○ NOT AVAILABLE

♿ Closer available with less than 5.0 lbs. opening force on 36" door.
* Maximum opening with standard template.
** Advanced Variable Backcheck.

4510T Series

Mounting details

Hinge (Pull Side) Mounting

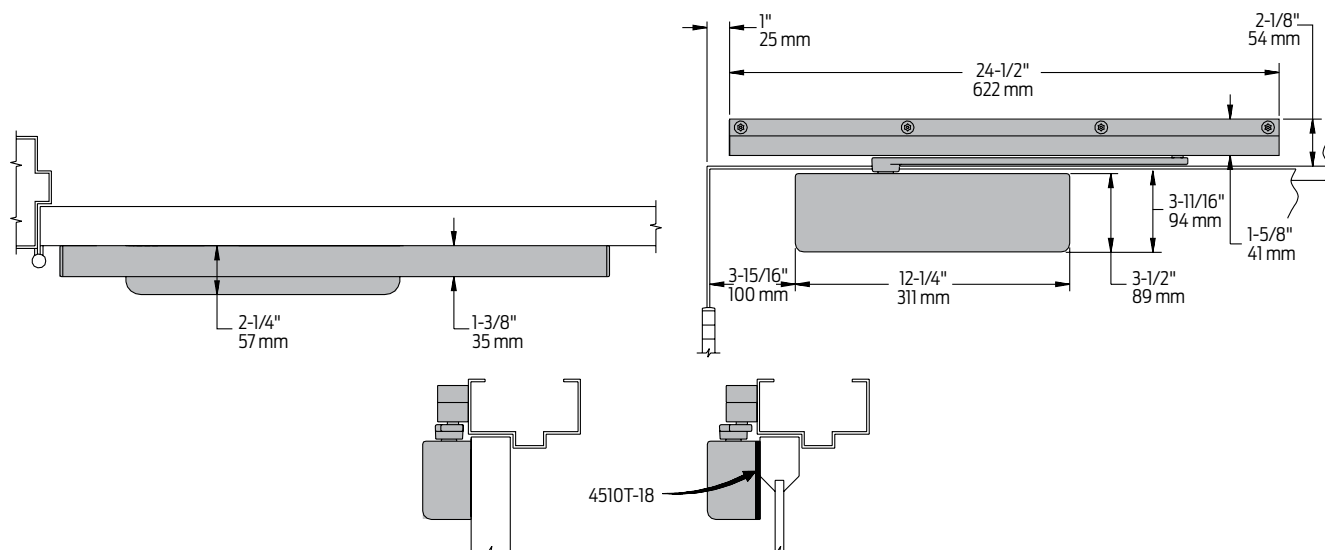

Butt Hinges	Should not exceed 5" (127 mm) in width
Auxiliary Stop	Recommended where a door cannot swing 180°
Reveal	Should not exceed 1/8" (3 mm)
Top Rail	<ul style="list-style-type: none"> Less than 3-3/4" (95 mm), requires PLATE 4510T-18 Plate requires 2" (51 mm) minimum top rail
Head Frame	Minimum 2-1/8" (54 mm)
Clearance	2-1/4" (57 mm) behind door required for installation
Advanced Variable Backcheck	<ul style="list-style-type: none"> Cylinder starts backcheck at approximately 45° instead of the normal 75° Add suffix "AVB" to selected cylinder (eg. 4513T AVB)
Maximum opening	<ul style="list-style-type: none"> Templating allows 180° Consult factory if door will be held open at 180°.
Options	Advanced Variable Backcheck cylinder

Cylinder



4511T(3)(4)
Cylinder Assembly

- Handed
- Cast iron
- Standard

Cover



4510T-72MC
Metal Security Cover

- Handed
- Four point TORX mounting for extra security
- Closer adjustments not accessible with cover installed

Arms



4510T-3077T
Standard Security Arm

- Handed
- Solid forged steel, large cross section arm
- Special threaded attachment of track roller for potentially abusive installations
- Double slab arm/pinion attachment for maximum strength
- Can only be used with high security track roller, 4510T-3034

Track



4510T-3038
Security Track

- Non-handed
- Designed to eject foreign objects placed in track during either opening or closing motion
- Requires track roller, 4510T-3034



4510T-3034
Security Track Roller

- Low friction track roller threads into 4510T-3077T arm for extra strength and security
- Can not be removed without disconnecting arm from closer

Installation Accessories



4510T-18
Plate

- Required where top rail is less than 3 3/4" (95 mm)
- Requires minimum 2" (51 mm) top rail

How-to-order 4510T Series

Table of sizes

- Select closer based on width of door
- Sized 4510T Series cylinders available in size 1, 3 or 4
- Closing power of all 4510T Series closers may be increased 15%

Select cylinder size

- 4511T (ADA)
- 4513T
- 4514T

Select hand

- RH
- LH

Specify finish

- Standard Powder Coat _____
Aluminum, Dark Bronze, Statuary, Light Bronze, Black, Brass

Closer will be shipped with:

- Standard cylinder
- Security cover
- Standard security arm
- Security track roller
- Security track
- TORX machine screw pack, unless options listed below are selected.

NOTE: Installation of this closer requires T-27 and T-25 driver bits for TORX machine screws with a security pin. Sold separately.

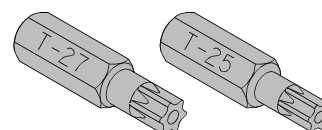

Closer options

Cylinder

- Advanced Variable Backcheck (AVB)

Finishes

- Custom Powder Coat (RAL) _____
- Plated Finish, US _____
- SRI primer (use with powder coat finishes only)

Screw pack

- TB* and TORX Machine Screw (TBTRX)
*Specify door thickness if other than 1-3/4".

Installation accessories

- PLATE, 4510T-18

Special template

- ST- _____

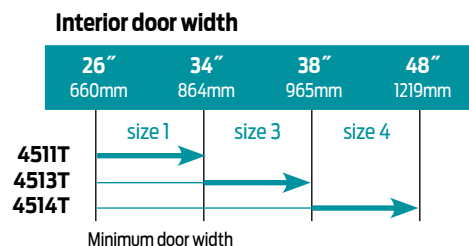

Note: Minimum door width 30" (762mm).

Reduced opening force 4510T Series closers

CAUTION! Any manual door closer, including those certified by BHMA to conform to ANSI Standard A156.4, that is selected, installed and adjusted based on ADA or other reduced opening force requirements may not provide sufficient power to reliably close and latch a door.

Refer to POWER OPERATORS section for information on systems that meet reduced opening force requirements without affecting closing power.

* Maximum opening force.

	DOOR WIDTH	36"	42"	48"
	8.5* lbs.	4513T	4513T	4513T
5.0* lbs.	4511T	4511T	4511T	

* Maximum opening force.